

# Height Gage

A standard measuring tool of industry

## Vernier Height Gage SERIES 514, 506 — Standard Height Gage with Adjustable Main Scale

- Fits comfortably in the hand and moves easily on the surface plate.
- The main scale slides and clamps within the column for quick and convenient zero-setting.
- Large locking knobs are used both for the slider and fine adjustment clamps to make clamping easy and secure.
- Operability of slider has been improved.

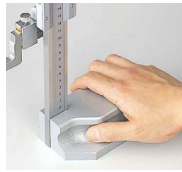

- Large main-scale engraving for fatigue-free working.
- Carbide-tipped scriber (07GZA000 for 514-102/104/106/103/105/107, 905200 for 514-108 and 109) is provided as a standard accessory. (Scriber clamp 05GZA033 for 514-102/104/106/108/103/105/107/109)
- It is important for personal safety to ensure that any height gage remains stable in use after attaching an accessory such as a test indicator or probe.
- For precision Black Granite Surface Plates, refer to page E-49.

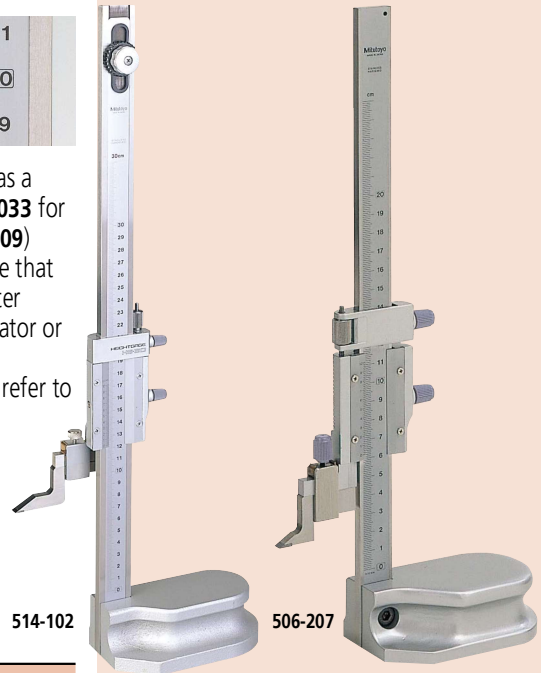
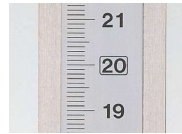

### SPECIFICATIONS

Metric								
Order No.	Range (mm)	Minimum reading (mm)	Scale adjustment (mm)	Fine feed (mm)	Maximum Permissible Error* (mm)/E <sub>MPE</sub>	Height (mm)	Mass (kg)	Remarks
506-207	0 - 200	0.02	—	4	±0.03	341	1.4	—
514-102	0 - 300		15		7	±0.04	525	3.1
514-104	0 - 450			6	±0.05	675	3.4	—
514-106	0 - 600			7	±0.07	870	7.4	—
514-108	0 - 1000		25	6	±0.07	1340	20	—

\* Maximum Permissible Error,  $E_{MPE}$ , is the term (notation) used in JIS B 7517: 2018, revised based on ISO/TR 14253-6: 2012.

Inch / Metric								
Order No.	Range (in)	Minimum reading	Scale adjustment (in)	Fine feed (in)	Maximum Permissible Error* (in)/E <sub>MPE</sub>	Height (mm)	Mass (kg)	Remarks
506-208	0 - 8	0.001 in/0.02 mm	—	0.16	±0.001	341	1.4	—
514-103	0 - 12		0.6		0.27	±0.002	525	3.1
514-105	0 - 18			1	±0.003	675	3.4	—
514-107	0 - 24			0.24	±0.003	870	7.4	—
514-109	0 - 40		1	0.24	±0.003	1340	20	—

\* Maximum Permissible Error,  $E_{MPE}$ , is the term (notation) used in JIS B 7517: 2018, revised based on ISO/TR 14253-6: 2012.

### DIMENSIONS

