

## Calipers

### ABSOLUTE Inside Caliper SERIES 536 — Knife-edge/Inside Groove/Point Jaw Type

- Dedicated caliper for inside measurement.

Knife-edge type

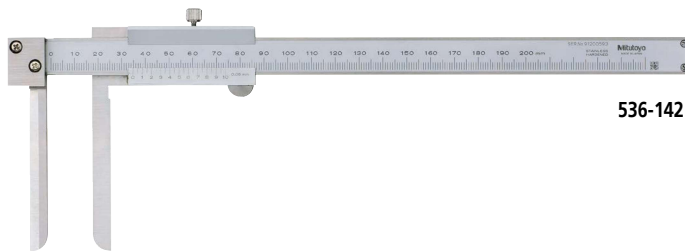

536-142

Inside groove type

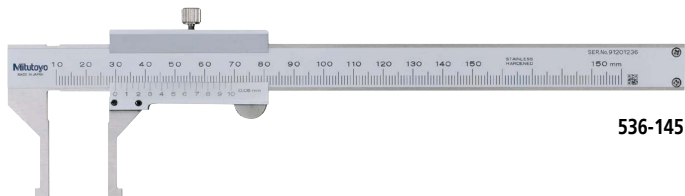

536-145

Point jaw type

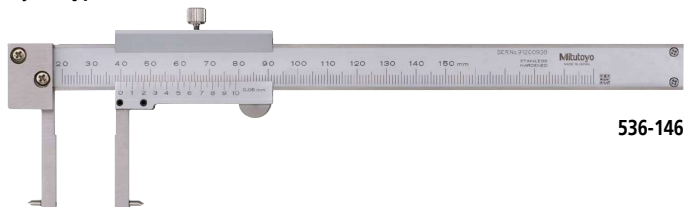

536-146

## SPECIFICATIONS

Metric Analog model

Order No.	Range (mm)	Graduation (mm)	Maximum permissible error (mm)*		Remarks
			$E_{MPE}$	$S_{MPE}$	
536-142	10 - 200	0.05	/	±0.12	Knife-edge type, Measurable min.
536-145	10.1 - 150			±0.05	Inside groove type, Measurable min.
536-146	20.1 - 150			±0.05	Point jaw type, Measurable min.
536-147	30.1 - 300			±0.08	Point jaw type, Measurable min.
536-148	70.1 - 450			±0.10	Point jaw type, Measurable min.
536-149	70.1 - 600			±0.12	Point jaw type, Measurable min.

\* Partial Surface Contact Error,  $E_{MPE}$  and Shift Error,  $S_{MPE}$  are terms (notations) used in ISO 13385-1:2019.

## DIMENSIONS

### Knife-edge type: 536-142

Unit: mm

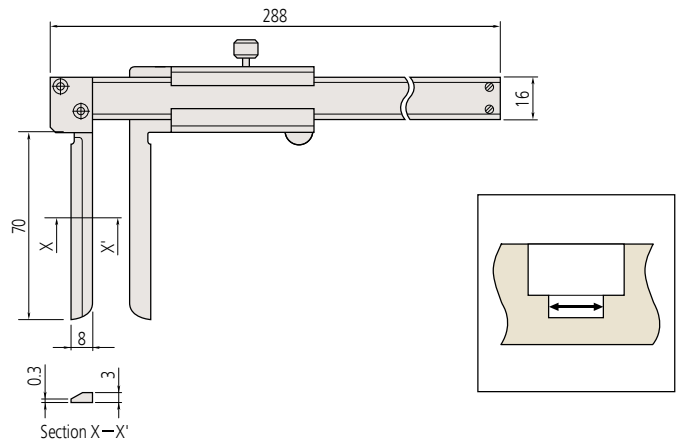

### Inside groove type: 536-145

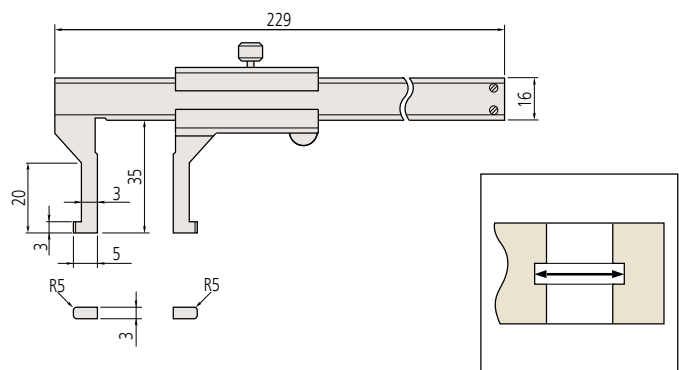

### Point jaw type: 536-146, 147, 148, 149

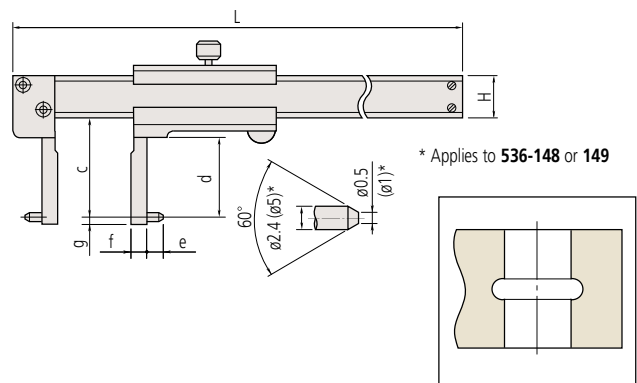

\* Applies to 536-148 or 149

Range (mm)	c	d	e	f	g	H	L
150	38	31	5	5	2	16	229
300	98	89	5	10	2	20	403
450	145	136	10	25	5	25	610
600	145	136	10	25	5	25	750

Note: Models with a measuring range of more than 300 mm have slightly different appearance. For details, contact our Customer Support Center.