

Inside Micrometers
SERIES 145 — Caliper Type

Accessories for 145-185 / 186 / 193 / 194 (optional)

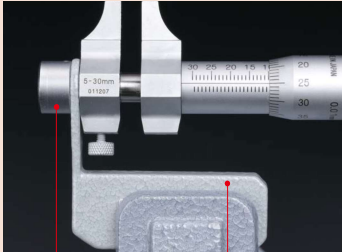

Cap (300401) Holder (300400)

Note 1: This instrument requires the cap and the holder for mounting on a micrometer stand.
Note 2: It may not be applicable to a custom specification.

- Carbide measuring faces.
- Equipped with a constant measuring-force device.
- Optional Setting Rings (nominal size below 300 mm), CERA Inside Micro Checker (more than 25 mm) and Gauge Block Accessory Sets are available as reference gages for datum adjustment. (Refer to pages C-28, C-52, and E-17 to E-20 for details)



145-185

DIMENSIONS

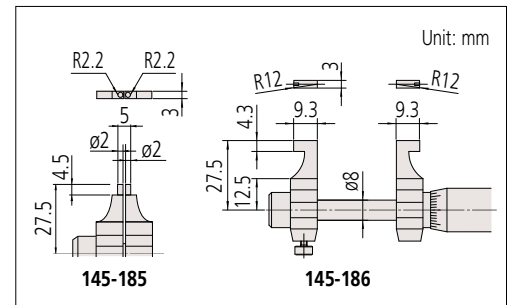

SPECIFICATIONS

Metric					
Order No.	Range (mm)	Graduation (mm)	Maximum permissible error J_{MPE} (μ m)	Jaw	Mass (g)
145-185	5 - 30	0.01	± 5	Pin	130
145-186	25 - 50		± 6	Anvil	140

Inch					
Order No.	Range (in)	Graduation (in)	Maximum permissible error J_{MPE} (in)	Jaw	Mass (g)
145-193	0.2 - 1.2	0.001	± 0.00025	Pin	130
145-194	1 - 2		± 0.0003	Anvil	140

Note: The minimum pitch circle measurement is $\varnothing 5$ mm with pin type (145-185, 145-193).



145-187

DIMENSIONS

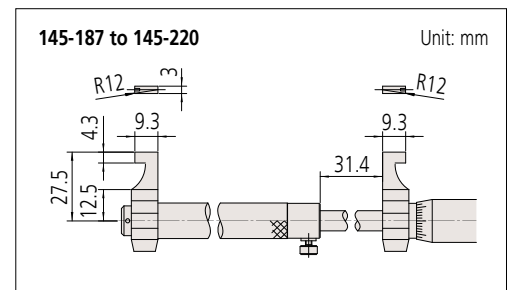

SPECIFICATIONS

Metric					
Order No.	Range (mm)	Graduation (mm)	Maximum permissible error J_{MPE} (μ m)	Jaw	Mass (g)
145-187	50 - 75	0.01	± 7	Anvil	160
145-188	75 - 100		± 8	Anvil	180
145-189	100 - 125		± 9	Anvil	210
145-190	125 - 150		± 10	Anvil	230
145-191	150 - 175		± 10	Anvil	250
145-192	175 - 200		± 10	Anvil	270
145-217	200 - 225		± 11	Anvil	310
145-218	225 - 250		± 11	Anvil	330
145-219	250 - 275		± 12	Anvil	350
145-220	275 - 300		± 12	Anvil	370

Inch					
Order No.	Range (in)	Graduation (in)	Maximum permissible error J_{MPE} (in)	Jaw	Mass (g)
145-195	2 - 3	0.001	± 0.00035	Anvil	160
145-196	3 - 4		± 0.0004	Anvil	180