

## Outside Micrometers SERIES 105 — with Anvil Extension Collars

### Extension collar

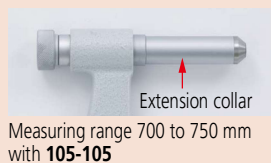

- Adjustable measuring range with extension collars.
- 50 mm/2 in spindle stroke.
- Measuring faces: Carbide.
- Equipped with Ratchet Stop for constant measuring force.



### SPECIFICATIONS

Metric							
Order No.	Range (mm)	Graduation (mm)	Extension Collars	Setting Standard	Spindle feed error (μm)	Flatness (μm)	Parallelism (μm)
105-103	500 - 600	0.01	1 pc. (50 mm)	2 pcs.	6	1.3	8
105-104	600 - 700						9
105-105	700 - 800						10
105-106	800 - 900						11
105-107	900 - 1000						12

- Standard Accessories: Spanner (200154), 1 pc.

# Micrometer

## Outside Micrometers SERIES 105 — with Anvil Extension Collars

- Large, lightweight micrometer with excellent strength based on a pipe-structure frame made of a combination of square and round pipes.
- Wide measuring range with anvil extension collars.
- 50 mm/2 in spindle stroke.
- Measuring faces: Carbide.
- Equipped with Ratchet Stop for constant measuring force.

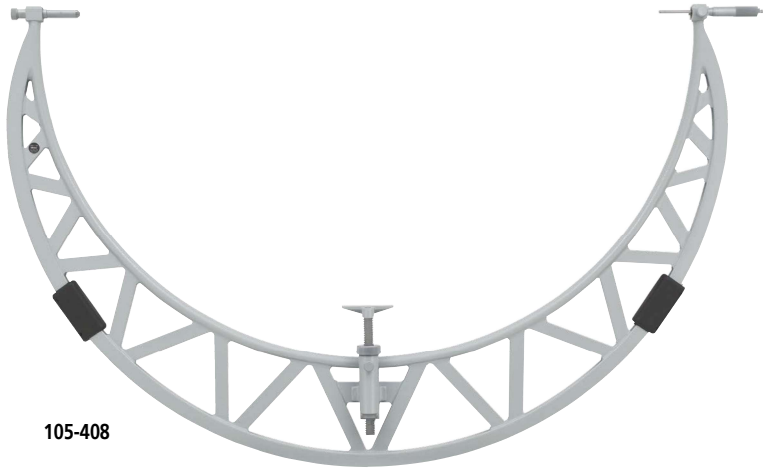

105-408

### SPECIFICATIONS

Metric							
Order No.	Range (mm)	Graduation (mm)	Extension Collars	Setting Standard (pcs.)	Spindle feed error (µm)	Flatness (µm)	Parallelism (µm)
(every 100 mm)							
105-408	1000 - 1100	0.01	1 pc. (50 mm)	2	6	1.3	13
105-409	1100 - 1200						14
105-410	1200 - 1300						15
105-411	1300 - 1400						16
105-412	1400 - 1500						17
105-413	1500 - 1600						18
105-414	1600 - 1700						19
105-415	1700 - 1800						20
105-416	1800 - 1900						21
105-417	1900 - 2000						22
(every 200 mm)							
105-418	1000 - 1200	0.01	2 pcs. (50 mm, 100 mm)	4 (every 50 mm)	6	1.3	14
105-419	1200 - 1400						16
105-420	1400 - 1600						18
105-421	1600 - 1800						20
105-422	1800 - 2000						22
Inch							
Order No.	Range (in)	Graduation (in)	Extension Collars	Setting Standard (pcs.)	Spindle feed error (in)	Flatness (in)	Parallelism (in)
105-428	40 - 44	0.001	1 pc. (2 in)	2	0.0003	0.000052	0.00052
105-429	44 - 48						0.00056
105-430	48 - 52						0.00060
105-431	52 - 56						0.00063
105-432	56 - 60						0.00067
105-433	60 - 64						0.00071
105-434	64 - 68						0.00075
105-435	68 - 72						0.00079
105-436	72 - 76						0.00083
105-437	76 - 80						0.00087

• Standard Accessories: Spanner (200154), 1 pc.

### Measurement example



**DIMENSIONS**

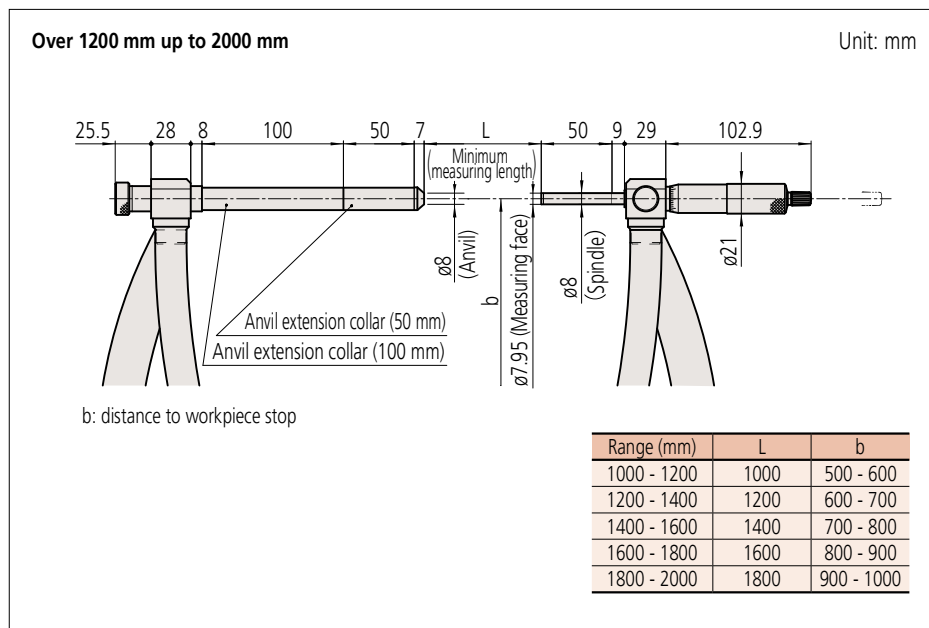

B