

Micrometer

Quickmike SERIES 293 — IP65 ABSOLUTE Digimatic Micrometers

- The Quickmike provides a speedy spindle feed of 10 mm per thimble rotation which enables widely differently sized features to be measured quickly.
- Set the origin only once. The absolute linear scale maintains the origin throughout the life of battery, meaning no more zero setting (presetting) or overspeed error.
- Measuring faces: Carbide.
- Supplied with a Ratchet Stop for constant measuring force.



293-666-20

SPECIFICATIONS

Metric

Order No.	Range (mm)	Resolution (mm)	Measuring force (N)	Maximum permissible error J_{MPE} (μ m)	Flatness (μ m)	Parallelism (μ m)	Constant measuring force	Mass (g)	Output function
293-666-20	0 - 30	0.001	5 - 12	± 2	0.3	2	Yes	275	With
293-667-20	25 - 55							340	
293-668-20	50 - 80			480					
293-669-20	75 - 105			585					

Inch / Metric

Order No.	Range (in)	Resolution	Measuring force (N)	Maximum permissible error J_{MPE} (in)	Flatness (in)	Parallelism (in)	Constant measuring force	Mass (g)	Output function
293-676-20	0 - 1.2	0.00005 in/ 0.001 mm	5 - 12	± 0.0001	0.000012	0.00008	Yes	275	With
293-677-20	1 - 2.2							340	
293-678-20	2 - 3.2			480					
293-679-20	3 - 4.2			585					

- SR44 (1 pc.), **938882**, for initial operational checks (standard accessory)
- Battery life: Approx. 5 years under normal use
- Approx. 18,000 hours in continuous use (1 year previous models **293-667/68/69/77/78/79**)
- Length standard: Electrostatic capacity absolute sensor
- Standard accessories: Setting standard, 1 pc. (except for measuring range 0 to 30 mm (0 to 1.2 in) models)
- Maximum response speed: without limit
- The non-rotating spindle enables even inexperienced operators to perform measurements repeatably and accurately.

DIMENSIONS

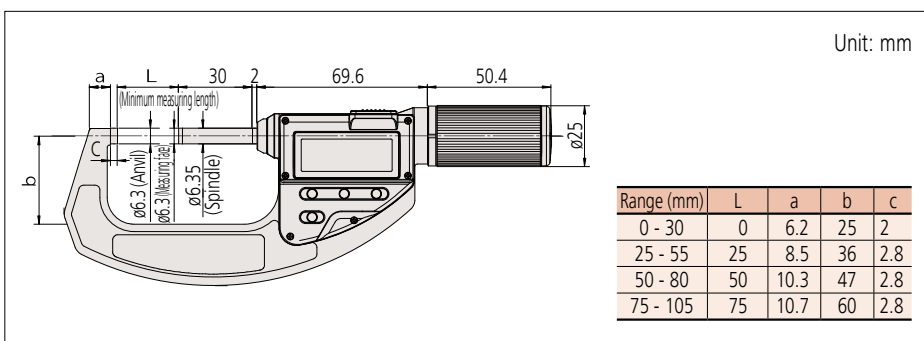

MeasurLink[®] ENABLED
Data Management Software by Mitutoyo

ABSOLUTE[™]



Dust and
Water-
Protected
www.tuv.com
ID 900063013

Measurement example



Optional Accessories

Order No.	Type	Description
05CZA662	B	Connecting cable (1 m)
05CZA663	B	Connecting cable (2 m)
06AFM380B	B	USB Input Tool Direct (2 m)
02AZD790B	B	Connecting cables for U-WAVE-T (160 mm)
02AZE140B	B	Connecting cables for U-WAVE-T For foot switch

Mechanism

