

# Micrometer

## Sheet Metal Micrometers SERIES 389

- Measures thickness of sheet metal.
- Measuring faces: Carbide.
- Profile of measuring faces: Flat-Flat, Spherical-Flat and Spherical-Spherical.
- Equipped with Ratchet Stop for constant measuring force.



### SPECIFICATIONS

Metric							
Order No.	Range (mm)	Resolution (mm)	Maximum permissible error $J_{MPE}$ (μm)	Flatness (μm)	Parallelism (μm)	Throat depth (mm)	Measuring surfaces
Digimatic (LCD)							
389-251-30	0 - 25	0.001	±4	0.6	3	150	F-F
389-261-30							S-F
389-271-30							S-S
389-514	25 - 50	0.001	±5	1	3	300*	F-F
389-252-30							S-F
389-262-30							S-S
389-272-30			±4	0.6		150	S-F
							S-S

Inch / Metric							
Order No.	Range (in)	Resolution	Maximum permissible error $J_{MPE}$ (in)	Flatness (in)	Parallelism (in)	Throat depth (in)	Measuring surfaces
Digimatic (LCD)							
389-351-30	0 - 1	0.0005 in/ 0.001 mm	±0.0002	0.000024	0.00012	6	F-F
389-361-30							S-F
389-371-30							S-S
389-714	1 - 2	0.0005 in/ 0.001 mm	±0.00025	0.00004	0.00012	12*	F-F
389-352-30							S-F
389-362-30							S-S
389-372-30			±0.0002	0.000024		6	S-F
							S-S

- Battery: SR44 (1 pc.), 938882, 2 pcs.: 389-514, 389-714 for initial operational checks (standard accessory)
- Battery life: Approx. 2.4 years under normal use (for 389-2XX, 3XX), Approx. 1.8 years under normal use (for 389-514, 714)
- Length standard: Electromagnetic rotary sensor
- Standard accessories: Setting standard, 1 pc. (except for measuring range 0 to 25 mm (0 to 1 in) models)  
Spanner (301336), 1 pc. (for 389-2XX, 3XX)  
Spanner (200154), 1 pc. (for 389-514, 714)

\* Models with a 300 mm (12 in) throat are equipped with a stand for convenience of measurement in the horizontal orientation as standard.

Note 1: For functional details of 389-251-30/389-252-30/389-351-30/389-352-30 refer to page B-7.

Note 2: For functional details of 389-514/389-714 refer to page B-9.

Note 3: In spherical-flat anvil type micrometers, the measuring face on the anvil side is spherical.

### DIMENSIONS

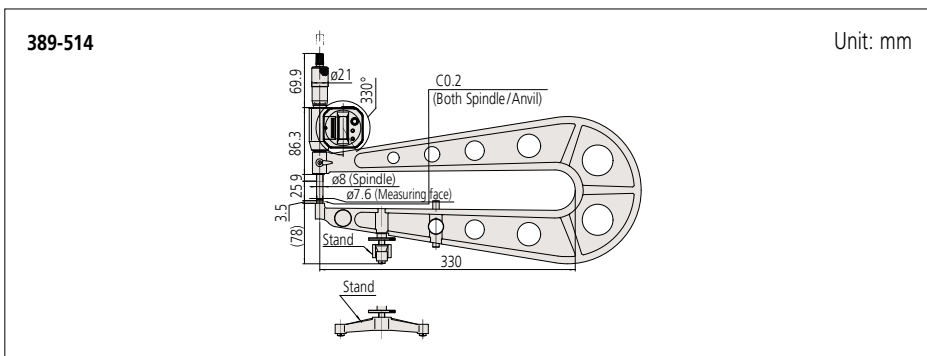

MeasurLink<sup>®</sup> ENABLED  
Data Management Software by Mitutoyo

U-WAVE<sup>fit</sup>

IP65

TUV Rheinland  
CERTIFIED

Dust and  
Water-  
Protected  
www.tuv.com  
ID: 0000910191

Applicable models: series 389  
(excluding 389-514 and 389-714)

### Optional Accessories

Order No.	Type	Description
05CZA662	B	Connecting cables (1 m) : for series 389
05CZA663	B	Connecting cables (2 m) : for series 389
06AFM380B	B	USB Input Tool Direct (2 m)
02AZD790B	B	Connecting cables for U-WAVE-T (160 mm): for series 389
02AZE140B	B	Connecting cables for U-WAVE-T: for series 389 For foot switch
04AZB512	CR	Connecting cable (1 m) : for 389-514
04AZB513	CR	Connecting cable (2 m) : for 389-514
959149	C	Connecting cable (1 m) : for 389-514
959150	C	Connecting cable (2 m) : for 389-514
264-622	IP67	U-WAVE-TM*
264-623	Buzzer	U-WAVE-TM*
264-626	IP67	U-WAVE-TMB
264-627	Buzzer	U-WAVE-TMB
02AZF310	IP67/ buzzer	Connecting unit for U-WAVE-TM/TMB*

\* Cannot be used with 389-514.

